

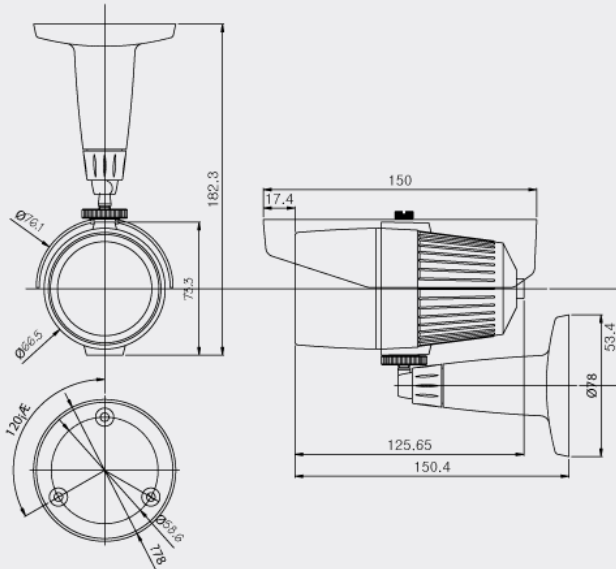

Features

- 1/3 inch High Sensitivity CCD
- High Resolution : 600 TV Lines
- Built-in Vari-focal Lens (f=3.8~9.5mm)
- Intelligent IR Technology
- Built-in IR LED(18EA)
- TDN(ICR)
- Min Illumination : Night(0.00Lux, IR LED On)
- Auto White Balance
- Weather Proof Housing
- 65mm in Diameter
- 12VDC
- IP66

DIMENSIONS



SPECIFICATIONS

Model	WCM-20VF	WCM-21VF
Signal System	NTSC	PAL
Scanning System	2:1 Interlace	
Scanning Frequency (H)	15.734 KHz	15.625 KHz
Scanning Frequency (V)	59.94 Hz	50 Hz
Image Sensor	1/3 Inch High Sensitivity CCD	
Total Pixels	811(H) x 508(V) 410K	795(H) x 596(V) 470K
Effective Pixels	768(H) x 494(V) 380K	752(H) x 582(V) 440K
Horizontal Resolution	600 TV Lines (BW 650TV Lines)	
Video Output	1.0V p-p (75Ω, Composite)	
S/N Ratio	More than 50dB(AGC Off)	
Lens	Vari-focal Lens (f=3.8~9.5mm)	
Min.Illumination	0.05 Lux (Color), 0.005 Lux (B/W), 0.00 Lux (IR LED On)	
IR LED and Sensor	Intelligent IR Technology, IR LED 18EA (850nm, 30°)	
IR LED Visible Range	Max. 20m	
Day&Night (ICR)	Auto	
Digital Noise Reduction	Low, Middle, High, Off	
White Balance	Auto	
AGC	On/Off (Dip Switch)	
Shutter Speed	1/60~1/120,000 Sec.	1/50~1/120,000sec.
Supplied Voltage	12VDC	
Power Consumption	Max. 6W/0.5A	
Dimensions(ØxH)	78.0 x 150.0mm	
Weight	Approx. 800g	