

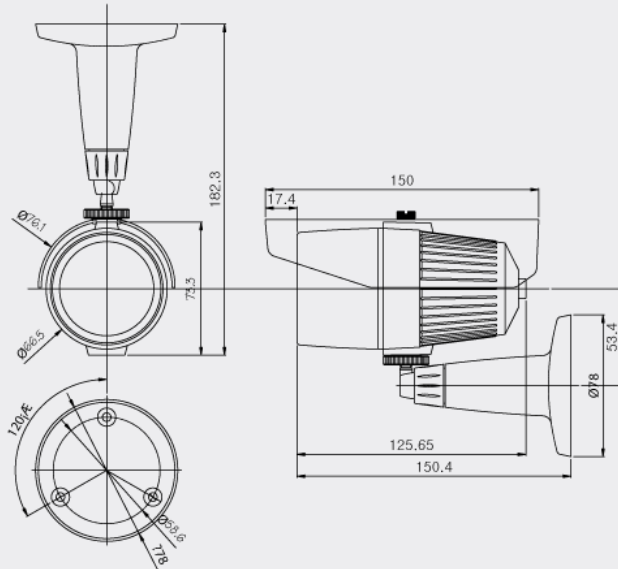

Features

- 1/3 inch Format CCD Imager
- High Resolution : 600 TV Lines
- Built-in Fixed Lens (f=6mm)
- Intelligent IR Technology
- Built-in IR LED(36EA)
- Min Illumination : 0.00Lux (IR LED On)
- Auto White Balance
- Weather Proof Housing
- 65mm in Diameter
- 12VDC

DIMENSIONS



SPECIFICATIONS

Model	WCL-20S	WCL-21S
Signal System	NTSC	PAL
Scanning System	2:1 Interlace	
Scanning Frequency (H)	15.734 KHz	15.625 KHz
Scanning Frequency (V)	59.94 Hz	50 Hz
Image Sensor	1/3 Inch Format CCD Imager	
Total Pixels	811(H) x 508(V) 410K	795(H) x 596(V) 470K
Effective Pixels	768(H) x 494(V) 380K	752(H) x 582(V) 440K
Horizontal Resolution	600 TV Lines (BW 650TV Lines)	
Video Output	1.0V p-p (75Ω, Composite)	
S/N Ratio	More than 50dB(AGC Off)	
Lens	Built-in Fixed Lens (f=6mm)	
Min.Illumination	0.05 Lux (Color), 0.00 Lux (IR LED On)	
IR LED and Sensor	Intelligent IR Technology, IR LED 36EA (850nm, 30')	
IR LED Visible Range	Max. 30m	
White Balance	Auto	
Shutter Speed	1/60-1/120,000 sec.	1/50-1/120,000 sec.
Supplied Voltage	DC 12V	
Power Consumption	Max. 6W/0.5A	
Dimensions	78.0 x 150.0mm	
Weight	Approx. 800g	