



# CNB-BE4815NVR/BE4815PVR

Weather Proof IR Camera



## Features

- 1/3 inch SONY Super HAD CCD
- High Resolution : 550TV Lines
- DC Iris Varifocal lens (f=3.8~9.5m F1.2)
- **Built-in IR LED (56EA) & Sensor(1EA)**
- True Day&Night (ICR)
- **SDNR(Super Digital Noise Reduction)**
- Electronic sensitivity-up (DSS)
- Auto White Balance
- AGC/BLC/Flickerless (On/Off)
- Min : Day(0.3Lux), Night(0.00Lux,IR LED On)
- Extra Video Out Port for Installer
- Weather-proof Housing
- AC24V/DC12V Dual Voltage
- Built in Fan/Heater



## DIMENSIONS

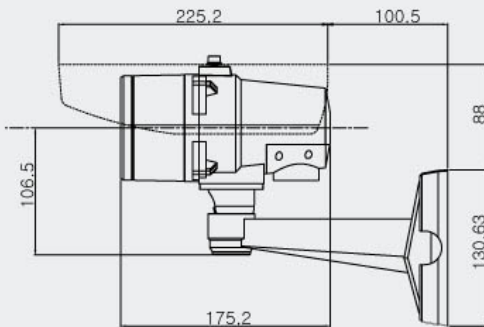
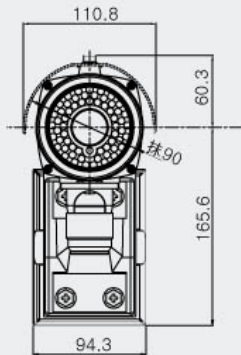

## SPECIFICATIONS

Model	CNB-BE4815NVR	CNB-BE4815PVR
Signal System	NTSC	PAL
Scanning System	2:1 Interlace	
Scanning Frequency (H)	15.734 KHz	15.625 KHz
Scanning Frequency (V)	59.94 Hz	50 Hz
Image Sensor	1/3 Inch SONY Super HAD CCD	
Total Pixels	811(H) x 508(V) 410K	795(H) x 596(V) 470K
Total / Effective Pixels	768(H) x 494(V) 380K	752(H) x 582(V) 440K
Horizontal Resolution	550 TV Lines	
Video Output	1.0V p-p (75Ω, Composite)	
S/N Ratio	More than 50dB(AGC Off)	
Lens	DC Iris Varifocal Lens (f=3.8~9.5mm F1.2)	
Digital Zoom Ratio	2x (On/Off)	
Min.Illumination	Day (0.3Lux), Night(0.00Lux, IR LED On)	
IR LED and Sensor	IR LED 56EA (850nm, 15°, 30° Mixed), Sensor 1EA	
IR LED Visible Range	Max. 50m	
Day&Night (ICR)	ICR (Sensor Type)	
DSS	On/Off (Max. 32FLD)	
White Balance	Auto	
AGC,BLC, Flickerless	On/Off	
IP Rating	IP65	
Supplied Voltage	AC 24V or DC 12V Dual Voltage	
Dimensions(WxHxD)	110.8 x 218.6 x 325.7 mm	
Weight	Approx. 1.6kg	